

REVISIONS			
REV.	DESCRIPTION	DATE	APPROVED
-	NEW RELEASE	-	-
1	MOUNTING BRACKET WAS FABRICATED NOW PURCHASED. REPLACED COMPRESSION PLATE WITH 2 PLATE WASHERS.	4/23/2026	F. BRYANT

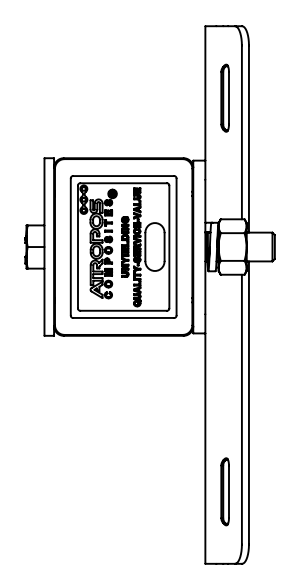
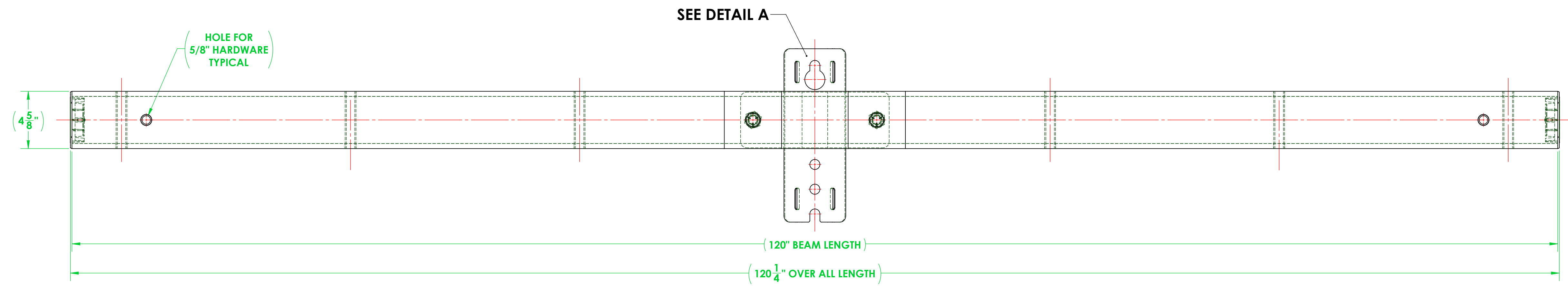
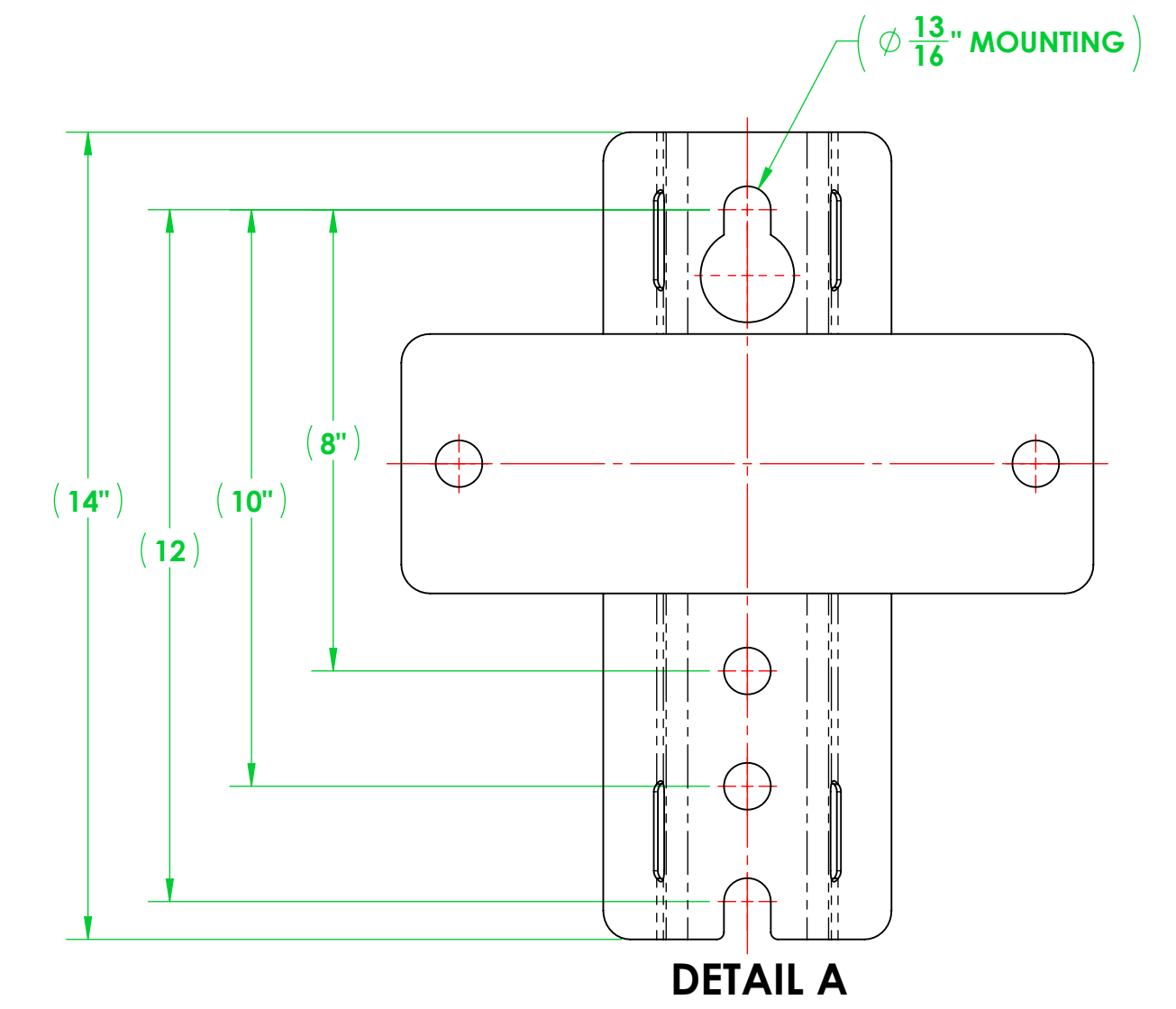
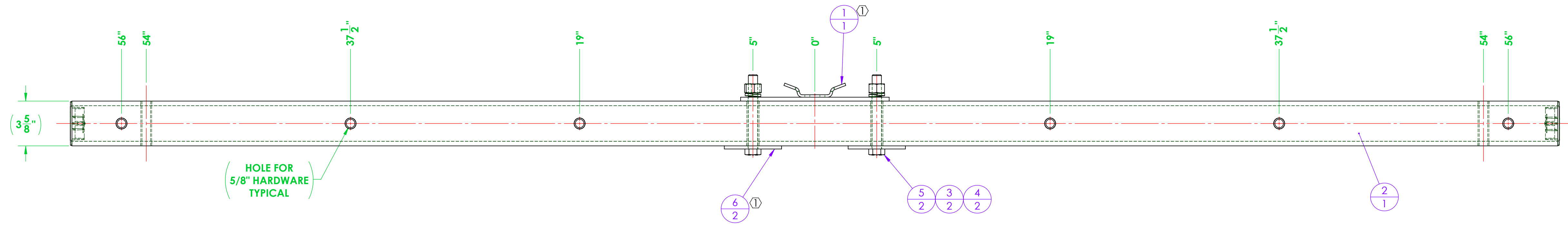

ITEM NO.	PART NUMBER	DESCRIPTION	QTY.
① 1	A700-0042	CROSSARM MOUNTING BRACKET, TANGENT, 3400 SERIES	1
2	3403A120-T011-X903 CA	ASSEMBLY, RUS, 3403 TANGENT CROSSARM, 10' LONG TYPE 5 DRILL PATTERN	1
3	A616-0042-01	LOCK WASHER, FOR 3/4" SCREW, 0.766" ID, 1.265" OD, 0.188" THICK, HOT-DIPPED GALVANIZED STEEL	2
4	A616-0019-02	EXTREME STRENGTH NUT, HEX, 3/4"-10, 2H, HOT-DIPPED GALVANIZED	2
5	A616-0020-02	BOLT, HEX, 3/4"-10 X 6.00" LONG, HOT DIPPED GALVANIZED STEEL, 1-1/8" DRIVE	2
① 6	A700-0047	WASHER, SQUARE, 4.625" X 4.625" X 0.25 THICK WITH 0.81 THRU HOLE	2

GENERAL NOTES DIMENSIONS ARE IN INCHES STANDARD TOLERANCES FRACTIONAL: ±1/32 ANGULAR: MACHINED: ±0.5° BEND: ±2° TWO PLACE DECIMAL: ±0.03 THREE PLACE DECIMAL: ±0.005 INTERPRET GEOMETRIC TOLERANCING PER: ANSI Y14.5 MATERIAL: FINISH: DO NOT SCALE DRAWING	UNLESS OTHERWISE SPECIFIED NAME: F. BRYANT DATE: 10/14/2025 CHECKED: TJS 10/21/2025 ENG APPR: MFG APPR: Q.A.: PROPRIETARY AND CONFIDENTIAL	ATROPOS COMPOSITES 12208 MISSOURI BOTTOM ROAD, HAZELWOOD, MO 63042 PHONE: 314.714.4001 FAX: 314.895.1943 SALES@LABYRINTH-TECH.COM
	TITLE: ASSEMBLY, TANGENT, 3403, (6) WIRE, 10 FT.	
	SIZE DWG. NO. REV D 3403A120-T011-X903 1	
	SCALE: 1:8 WEIGHT: 83.23 SHEET 1 OF 1	